

Kreissägemotoren - Standardbauweise

Sawmotors - standard design

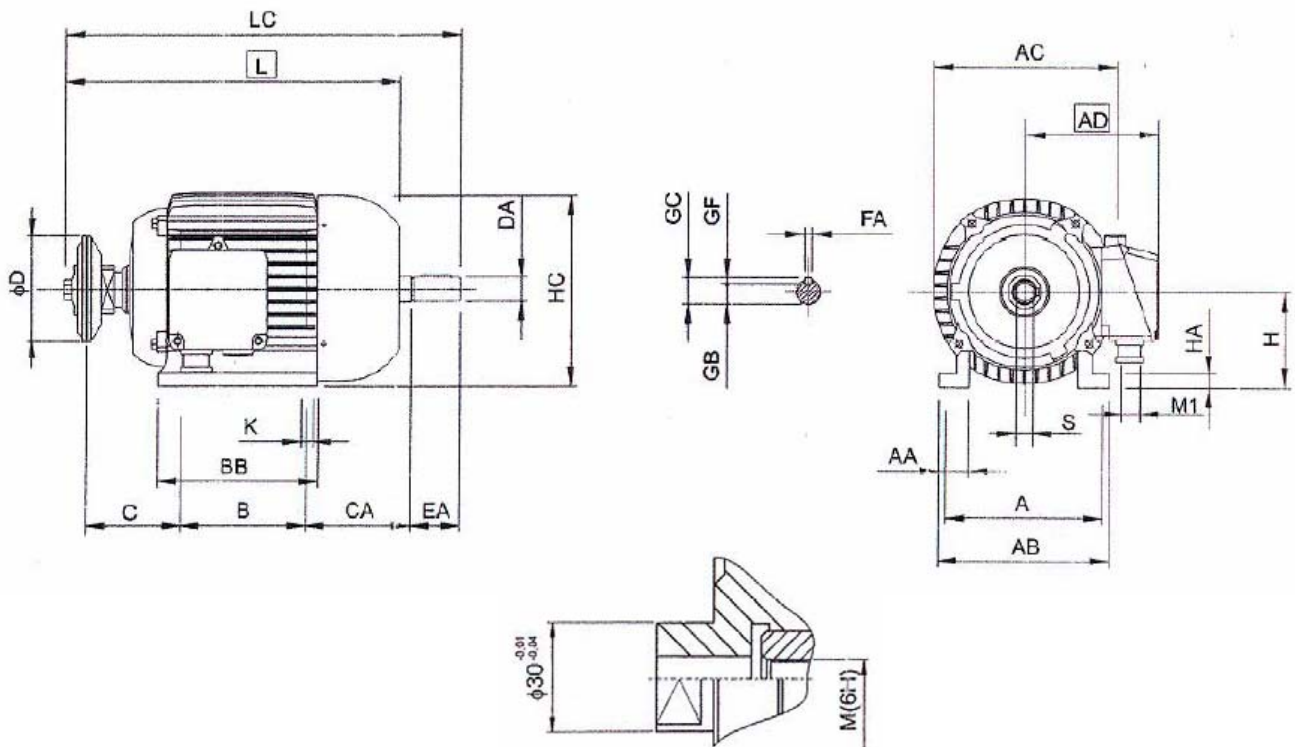

[kW]	[Upm]	Baugr Size	w	A	B	C	D	S	DA	EA	FA	GB	GC	GF	H	K	K 1	M	AA	AB	AC	AD	BB	CA	HA	HC	L	LC	M 1
3	2800	80	A	125	100	88,5	120	-	-	-	-	-	-	-	80	10	10	M10	32	146	158	140	170	-	10	150	360	-	M25 x1,5
3	2800	90 L	A	140	125	88,5	120	17	-	-	6	15,5	21,5	6	90	10	14	M10	38	164	158	132	145	-	10	169	337	-	
4	2800	100 L	A	160	140	104,5	142	19	-	-	8	24	31	7	100	12	20	M12	42	190	190	148	164	-	12	194	372	-	
4	1400	100 L	G	160	140	98,5	142	19	-	-	8	24	39	7	100	12	12	M12	36	190	206	142	178	-	12	200	364	-	
5,5	2800	112 M	G	190	140	105,5	142	19	-	-	8	24	31	7	112	12	12	M12	40	220	234	158	178	-	13	225	381	-	

A Aluminium
 G Grauguss / Cast Iron